

**"FPF08K" SERIES FAN FILTERS**

Description: **Fan Filter 115/230 Va.c.**



<b>Type of material:</b>	ABS/PC alloy
<b>Standard color:</b>	RAL 7032, RAL 7035 and RAL 9005 - other colors on request
<b>Protection degree:</b>	IP54, according to EN 60529 Std; Type 12, according to UL 508 Std
<b>Fixing system:</b>	by elastic hooks, otherwise by four 2.2 mm self-threading screws
<b>Plate thickness:</b>	from 1.5 mm to 2.2 mm
<b>Storage temperature:</b>	from -40°C to +70°C
<b>Motor Lifetime L10 at 40°C:</b>	45,000 h
<b>Motor protection:</b>	impedance
<b>Electrical connection:</b>	by 2 wires L-N, 22 AWG, color black
<b>Earth connection:</b>	(by M4 thread hole on fan's casing)
<b>Appliance class:</b>	Class I
<b>Type of filter media:</b>	thermo-linked progressive structure
<b>Filtering class:</b>	class G3, according to EN 779
<b>Degree of separation:</b>	85% - DIN 24185
<b>Dust retention capacity:</b>	600 g/m <sup>2</sup>
<b>Note:</b>	filter media is washable for about 10 times
<b>Weight:</b>	0.5 Kg
<b>Approvals:</b>	CE, UL E237844

**technical drawing**

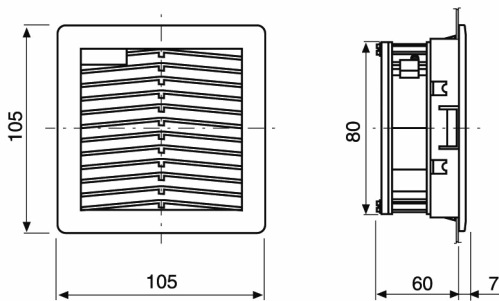

**mounting cut-out**

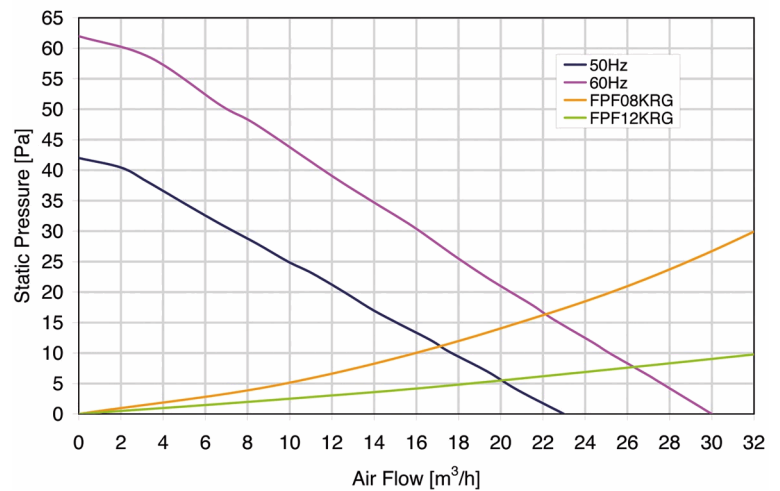
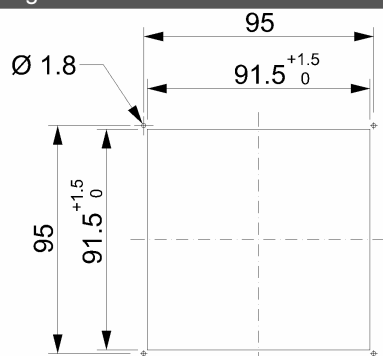

Model	Voltage (V)	Frequency (Hz)	Rated Current (A)	Rated Power (W)	Max Air Flow** (m3/h)	Static Pressure (Pa)	Fan Noise [db(A)]	Rated Temp. Range (°C)	Approvals
FPF08K*115B-110	115 V a.c.	50/60	0.115/0.092	9.0/7.0	23/30	42/62	33.0/38.0	-10 + +50	CE; cURus
FPF08KR115BR-110	115 V a.c.	50/60	0.115/0.092	9.0/7.0	23/20	42/62	33.0/38.0	-10 + +50	CE; cURus
FPF08KU115BR-110	115 V a.c.	50/60	0.115/0.092	9.0/7.0	23/30	42/62	33.0/38.0	-10 + +50	CE; cURus
FPF08K*230B-110	230 V a.c.	50/60	0.07/0.055	10/8.0	23/30	42/62	33.0/38.0	-10 + +50	CE; cURus
FPF08K*230BR-110	230 V a.c.	50/60	0.07/0.055	10/8.0	23/30	42/62	32.0/36.0	-10 + +50	CE; cURus

\* U = RAL 7035 R = RAL 7032 N = RAL 9005 \*\*data with uncertainty of 15%

All specifications, data and drawing are subject to change without notice. Please refer to our terms of sales including our warranty and limited liabilities clauses.