

FF15D24NN53

Type 3R version with fan

> CONTACT US



FF series exhaust filter and filter fans represents a side-mounted cooling solution with filtered ambient air to maintain optimum ventilation inside the electrical cabinets. Screwless connection, fast tool-free mounting system with clip and maintenance friendliness are the main benefits. Available in a wide range of configurations for both indoor and outdoor use.

Technical data		
APPROVALS		
Approvals	CE; UR; cULus; UKCA	
PERFORMANCE		
Max Airflow	205	m³/h
	121	CFM
Airflow with Exhaust Filter	130	m³/h
	77	CFM
Max Static Pressure	97	Pa
	0.39	in H2O
ELECTRICAL DATA		
Rated Voltage	24	V d.c.
Rated Current	0.71	A
Rated Power	17	W
Operating Voltage	17-28	V d.c.
Motor Protection	Electronically Protected	
MECHANICAL DATA		
Mounting Wall Thickness	1.3-3.7	mm
	0.05-0.15	in
Bearing	Ball Bearing	
GENERIC DATA		
Spare Parts Filter Media	M15FPPF	
Casing Material	PBT UL94 5VB	

Image is for illustrative purpose only. All specifications, data and drawing are subject to change without notice. Please refer to our terms of sales including our warranty and limited liabilities clauses.

FF15D24NN53

Type 3R version with fan

> CONTACT US

Technical data		
RAL Number	9005	
Life Expectancy	100000	h at 25 °C
	100000	h at 77 °F
Airflow Direction	Direct	
Electrical Connection	Screwless Terminal Block	
Wires Section	0.75-2.5	mm ²
Wires Section	20-14	AWG
Fan Noise	60	dB(A)
Filter Class	G4	EN 779
Filter Class	ISO coarse 75%	ISO 16890
Filter Material	thermo-linked progressive structure synthetic fibre	
ENVIRONMENTAL AND THERMAL DATA		
IP Protection Degree	IP55	
Operating Temperature	-10÷55	°C
	14÷131	°F
Storage Temperature	-40÷70	°C
	-40÷158	°F
UL DATA		
UL File Number Recognized Component	E237844	
UL File Number Listed	E500932	
UL Environmental Type Rating	Type 3R	
UL Surrounding Temperature	55	°C
	131	°F

Image is for illustrative purpose only. All specifications, data and drawing are subject to change without notice. Please refer to our terms of sales including our warranty and limited liabilities clauses.

Technical drawing mm (in)

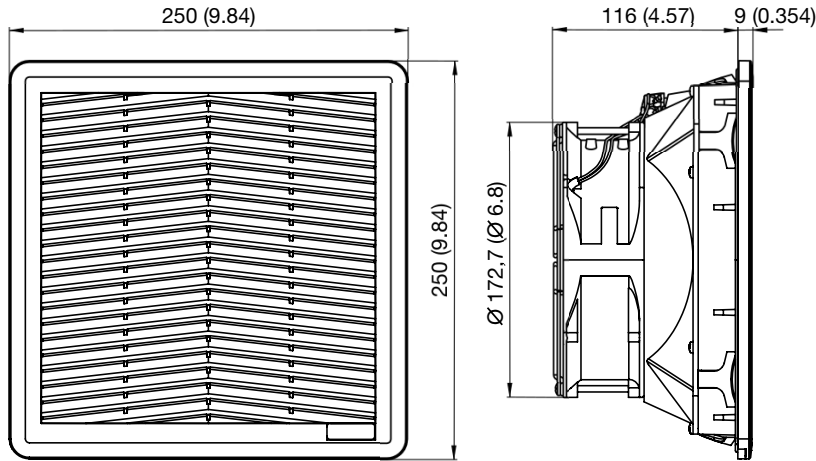

Mounting cut-out mm (in)

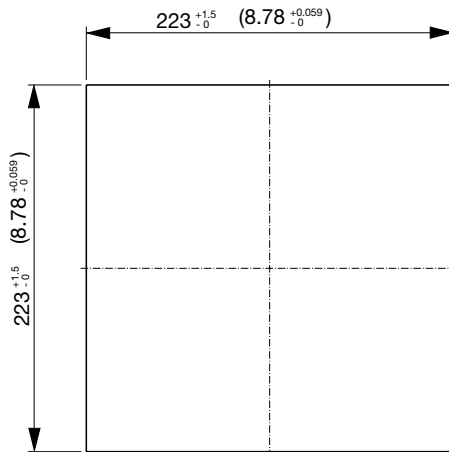

Image is for illustrative purpose only. All specifications, data and drawing are subject to change without notice. Please refer to our terms of sales including our warranty and limited liabilities clauses.

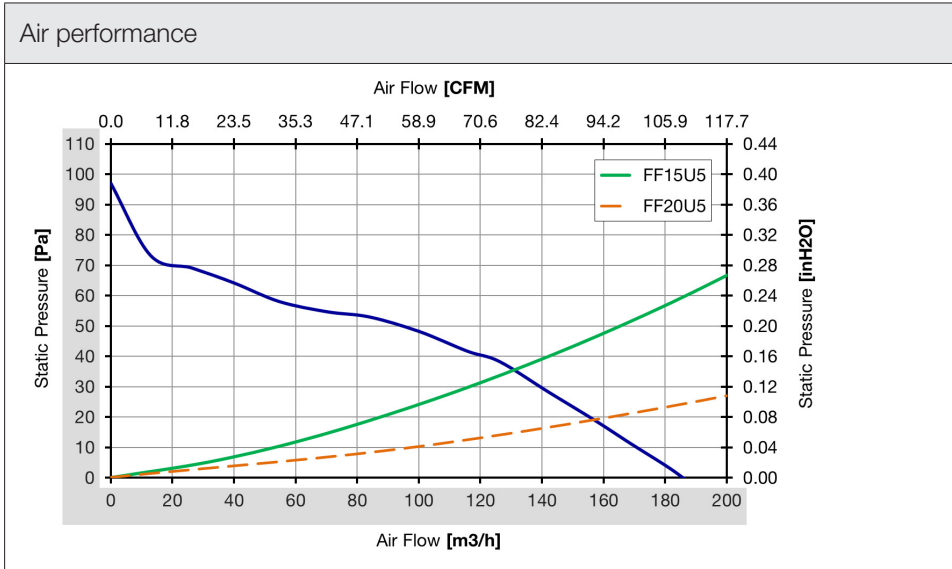

Image is for illustrative purpose only. All specifications, data and drawing are subject to change without notice. Please refer to our terms of sales including our warranty and limited liabilities clauses.