

A12B05HTBWFO

IP55 AC fans

> CONTATTACI



Axial fans provide forced-air cooling solution to temperature-sensitive applications. Compact fans with AC shaded pole or capacitor and DC brushless motor are designed for ventilation and spot cooling of internal machinery components, especially in areas in confined spaces. Available also versions tested to withstand harsh environmental conditions (IP55, IP68, all metal and HTR fans).

| Technical data | | |
|---------------------|---------------------------|---------------------------|
| APPROVALS | | |
| Approvals | CE; UKCA | |
| PERFORMANCE | | |
| Max Airflow | 141/165 83/97 | m ³ /h CFM |
| Max Static Pressure | 62/77 0.25/0.31 | Pa in H ₂ O |
| RPM | 2550/2800 | RPM |
| ELECTRICAL DATA | | |
| Rated Voltage | 24 | V a.c. |
| Rated Current | 0.8/0.77 | A |
| Rated Power | 14/14 | W |
| Operating Voltage | 19-26 | V a.c. |
| Frequency | 50/60 | Hz |
| Motor Protection | Impedance Protected | |
| MECHANICAL DATA | | |
| Bearing | Ball Bearing | |
| GENERIC DATA | | |
| Casing Material | Die-Casting Aluminium | |
| Life Expectancy | 30000 30000 | h at 40 °C h at 104 °F |
| Airflow Direction | Air exhaust over brackets | |

Image is for illustrative purpose only. All specifications, data and drawing are subject to change without notice. Please refer to our terms of sales including our warranty and limited liabilities clauses.

A12B05HTBWFO

IP55 AC fans

> CONTATTACI

| Technical data | | |
|--------------------------------|-----------------|-------|
| Electrical Connection | Fast-On 3x0,5mm | |
| Fan Noise | 45/48 | dB(A) |
| Fixing System | Screws | |
| ENVIRONMENTAL AND THERMAL DATA | | |
| IP Protection Degree | IP55 | |
| Operating Temperature | -10÷60 | °C |
| | 14÷140 | °F |
| Storage Temperature | -40÷70 | °C |
| | -40÷158 | °F |

Image is for illustrative purpose only. All specifications, data and drawing are subject to change without notice. Please refer to our terms of sales including our warranty and limited liabilities clauses.

A12B05HTBWFO

IP55 AC fans

> CONTATTACI

Technical drawing mm (in)

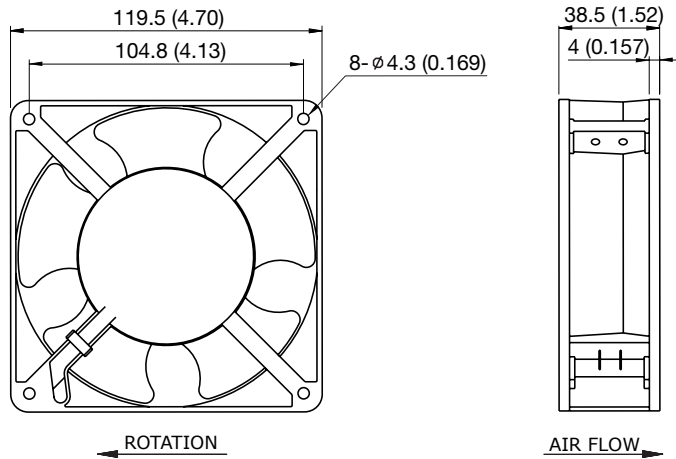

Air Performance

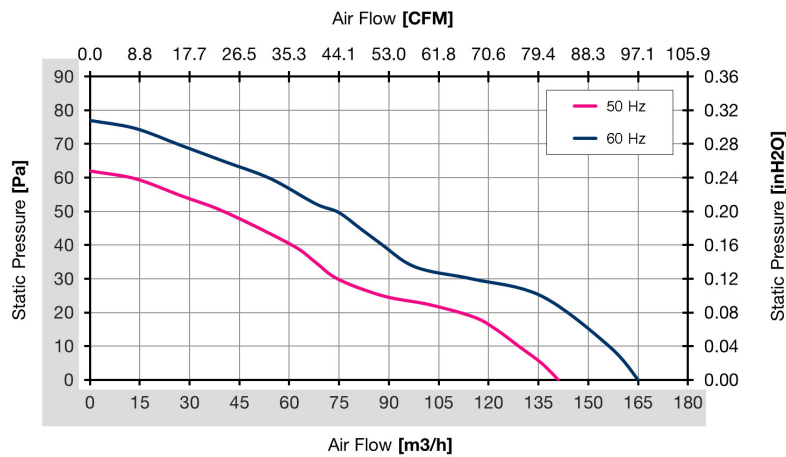

Image is for illustrative purpose only. All specifications, data and drawing are subject to change without notice. Please refer to our terms of sales including our warranty and limited liabilities clauses.